

Specifications

Standards Compliance

- ANSI A92.6
- CSA B354.2
- CE Compliance
- AS 1418.10

Genie United States

18340 NE 76th Street
P.O. Box 97030
Redmond, Washington 98073-9730

Telephone **(425) 881-1800**
Toll Free in USA/Canada **800-536-1800**
Fax (425) 883-3475

Genie United Kingdom

The Maltings
Wharf Road
Grantham NG31 6BH
U.K.

Telephone **+44 (0)1476 584333**
Fax +44 (0)1476 584334

www.genieindustries.com

Distributed By:

For further information, please contact your local distributor or the Genie Industries sales office listed. Continuous improvement of our products is a Genie policy. Product specifications are subject to change without notice or obligation. The photographs and drawings in this brochure are for illustrative purposes only. Refer to the appropriate Operator's Manual for instructions on the proper use of this equipment. Failure to follow the appropriate Operator's Manual when using our equipment, or to otherwise act irresponsibly, may result in serious injury or death. Prices and specifications subject to change without notice. The only warranty applicable is the standard written warranty applicable to the particular product and sale. Genie makes no other warranty, expressed or implied. Products and services listed may be trademarks, service marks or trade-names of TEREX Corporation and/or its subsidiaries in the USA and other countries and all rights are reserved. Copyright © 2005 Genie Industries, Inc. "Genie" is a Registered Trademark of Genie Industries, Inc. in the USA and many other countries. Genie is a TEREX Company. GS2646 5K 0305A. Part No. 109347

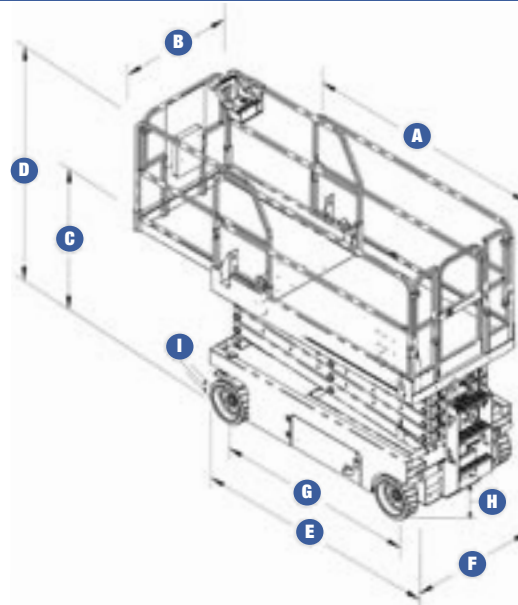

GS™-2646

	US	Metric
MEASUREMENTS:		
	Working height max*	32 ft / 9.9 m
	Platform height max	26 ft / 7.9 m
A	Platform length - outside	7 ft 5 in / 2.3 m
	Platform length - extended	10 ft 5 in / 3.2 m
B	Platform width - outside	3 ft 9.3 in / 1.2 m
	Guardrail height	3 ft 7 in / 1.09 m
	Roll-out platform extension	3 ft / .91 m
	Toeboard height	6 in / 15 cm
C	Height - stowed (platform)	3 ft 9.6 in / 1.2 m
D	Height - stowed - (folding guardrails)	7 ft 5 in / 2.3 m
	- rails folded	5 ft 6 in / 1.7 m
E	Length - stowed	7 ft 11 in / 2.4 m
	- extended	10 ft 10.5 in / 3.3 m
F	Width	3 ft 10 in / 1.2 m
G	Wheelbase	6 ft 1 in / 1.9 m
H	Ground clearance	4 in / 10 cm
I	- pothole guards deployed	.75 in / 1.9 cm
	Lift capacity	1,000 lbs / 454 kg
	Lift capacity - extension deck	250 lbs / 113 kg

PRODUCTIVITY:

Drive speed - stowed	2.2 mph	3.5 km/h
Drive speed - raised	0.5 mph	0.8 km/h
Gradeability**	30%	30%
Turning radius - inside	zero	zero
Turning radius - outside	7 ft 6 in	2.3 m
Raise / lower speed	30 / 24 sec	30 / 24 sec
Controls	proportional	proportional
Drive	dual front wheel	dual front wheel
Multiple disc brakes	dual rear wheel	dual rear wheel
Tires - solid non-marking	15 x 5 x 11 in	38 x 13 x 28 cm

POWER:

Power source	24 V (4 - 6 V 225 Ah batteries)	
Hydraulic tank capacity	6.5 gal	24.6 L
Weight*** ANSI/CSA	4,312 lbs	1,956 kg
CE/AUS	5,395 lbs	2,447 kg

* The metric equivalent of working height adds 2 m to platform height. U.S. adds 6 ft to platform height.

** Gradeability applies to driving on slopes, see operators manual for details regarding slope ratings.

*** Weight will vary depending on options and/or country standards.

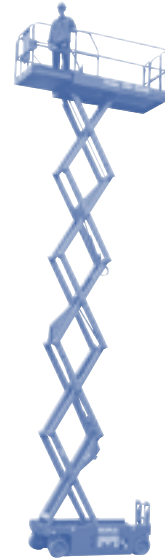

Easily Configured to Meet Your Needs:

PLATFORM OPTIONS

- Standard: steel 7 ft 5 in (2.3 m)
- Extension platform 3 ft (.91 m)

POWER OPTION

- 24 V (4 - 6 V 225 Ah Batteries)

DRIVE OPTION

- 2WD

TIRE OPTION

- Solid non-marking tires

Standard Features

MEASUREMENTS:

- GS™2646 has 32 ft (9.9 m) working height
- Up to 1,000 lbs (454 kg) lift capacity

POWER:

- Automatic battery charger

PRODUCTIVITY:

- 3 ft (.91 m) extension deck
- Folding rails with full-height swing gate
- Fully proportional controls
- On-board diagnostic system
- AC power to platform
- Electric horn
- Tilt level sensor
- Descent alarm
- Hour meter
- Dual wheel disc brakes
- Brake release
- Emergency stop at both platform and ground controls
- Manual platform lowering valve
- Swing out component tray
- Pothole guards
- Solid non-marking tires
- Lanyard attachment points

Options and Accessories

PRODUCTIVITY

- Air line to platform
- Platform work lights
- Pipe cradle for square guardrails
- Dual flashing beacons
- Control box covers
- Motion package
- Automotive style horn

POWER:

- Power inverter
- Maintenance-free batteries
- EE rating